

NOTE:
 IN THE ACTUAL VEHICLES, SOME OF THE J/C TERMINALS IN THE SAME BUS ARE USED,
 SO IN SOME CASES, THE TERMINAL ARRANGEMENT INDICATED ON THE CIRCUIT
 DIAGRAMS DOES NOT AGREE WITH THE ONES IN THE ACTUAL VEHICLES.
 AS FOR J/C (CAN1, 2), REFER TO CAN CIRCUIT.
 IN ADDITION, ON J/C (CAN1, 2), THE TERMINAL NUMBERS INDICATED ON THE CIRCUIT
 DIAGRAMS SHOULD ALWAYS AGREE WITH THE TERMINAL ARRANGEMENT IN THE ACTUAL
 VEHICLES.

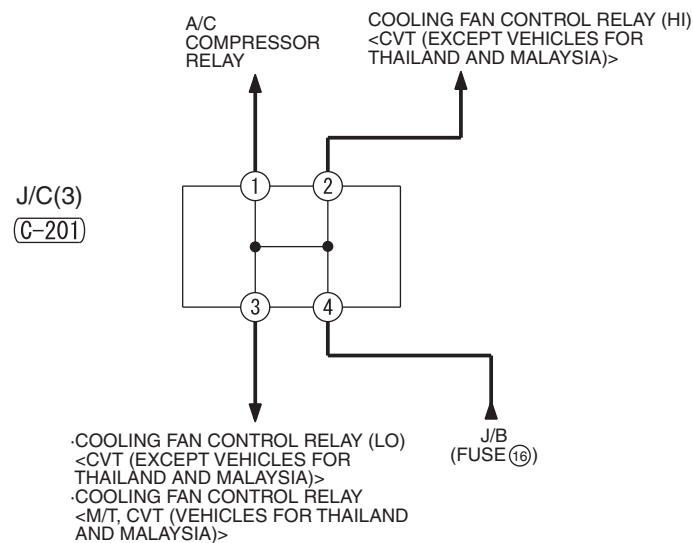

(A-106)

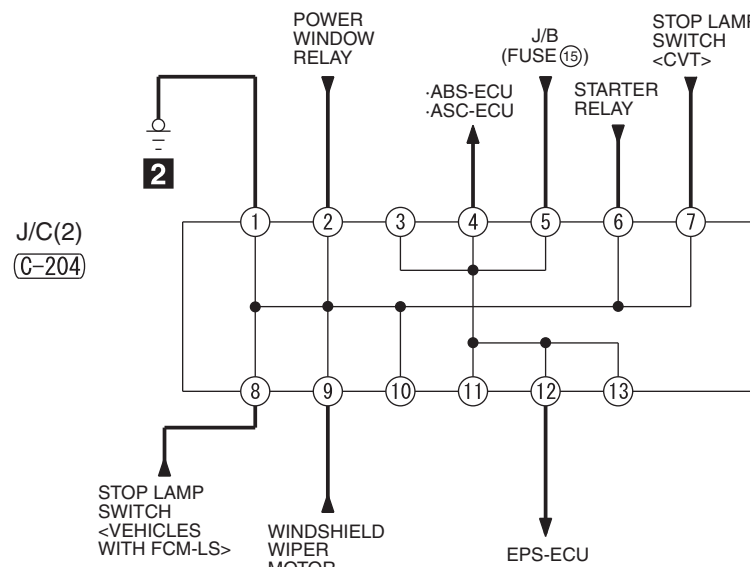
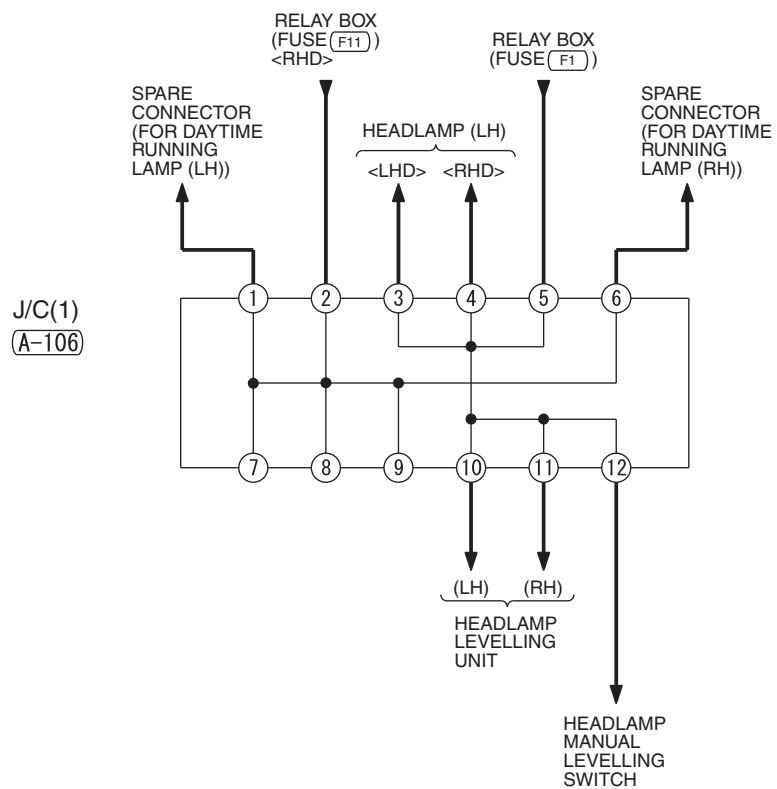
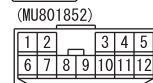

(C-201)



(C-204)

