

<VEHICLES WITHOUT DPF>

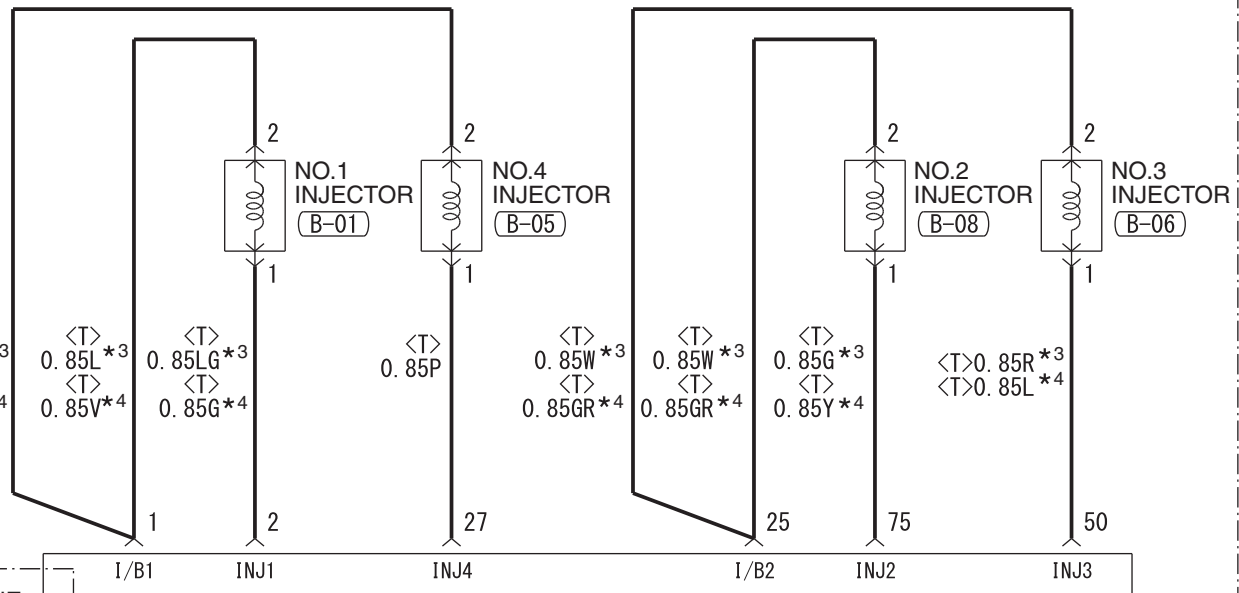

ENGINE-ECU (D-13)

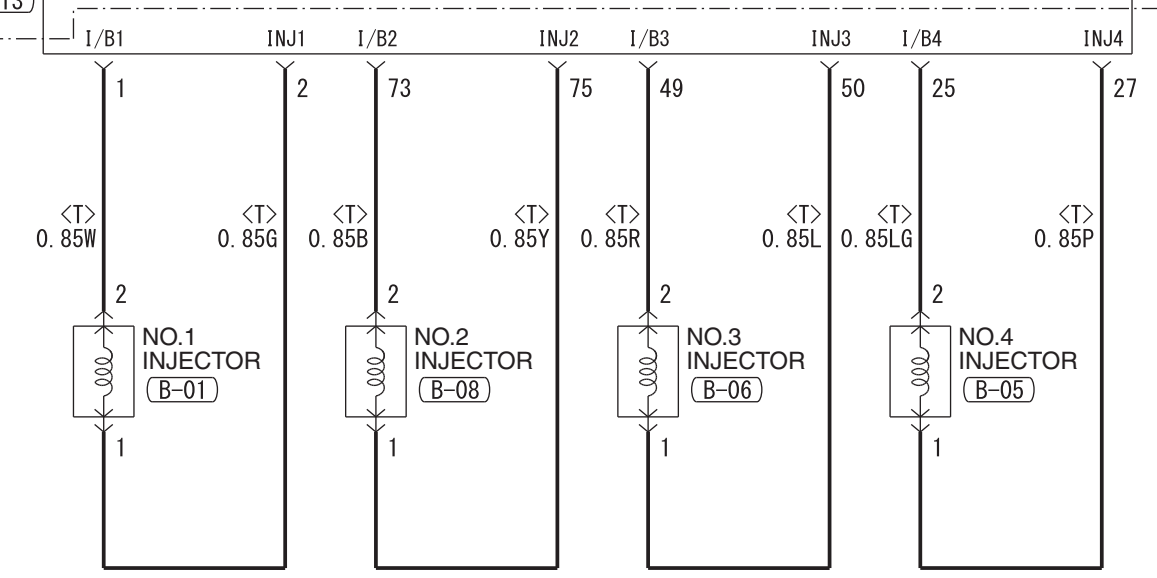

<VEHICLES WITH DPF>

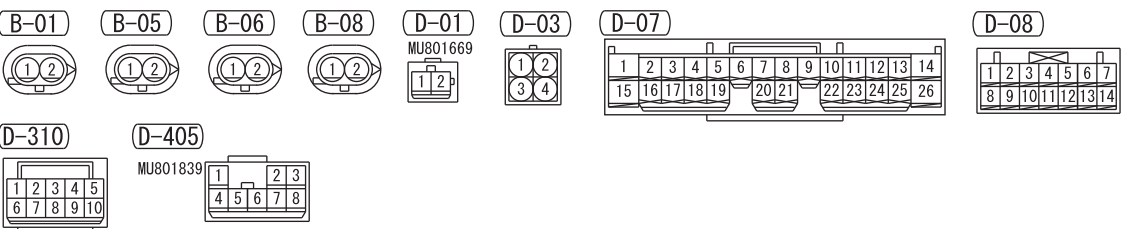

NOTE

- *3: 4D5
- *4: 4N1
- *5: VEHICLES WITH ADJUSTABLE SPEED LIMITER
- *6: A/C-ECU
- ASC OFF SWITCH
- BLIND SPOT WARNING SWITCH
- COMBINATION METER
- DRIVE MODE-SELECTOR
- E-CALL SWITCH
- ELECTRIC PARKING BRAKE SWITCH
- FORWARD COLLISION MITIGATION SYSTEM (FCM) AND ULTRASONIC MISACCELERATION MITIGATION SYSTEM
- ON/OFF SWITCH
- GLOVE BOX LAMP
- HAZARD INDICATOR ASSEMBLY
- HAZARD WARNING LAMP SWITCH
- HEADLAMP MANUAL LEVELLING SWITCH
- HEATED SEAT SWITCH (FRONT, SECOND)
- HEATED STEERING WHEEL SWITCH
- HEATER CONTROLLER ASSEMBLY
- HILL DESCENT CONTROL SWITCH
- MULTIVISION DISPLAY
- OFF-ROAD MODE SELECTOR
- RADIO AND CD PLAYER
- REAR COOLER CONTROL PANEL
- REAR DIFFERENTIAL LOCK SWITCH
- REAR DISPLAY UNIT
- REAR FAN SWITCH
- SELECTOR LEVER ASSEMBLY
- SMARTPHONE LINK DISPLAY AUDIO
- SONAR SWITCH

ENGINE-ECU

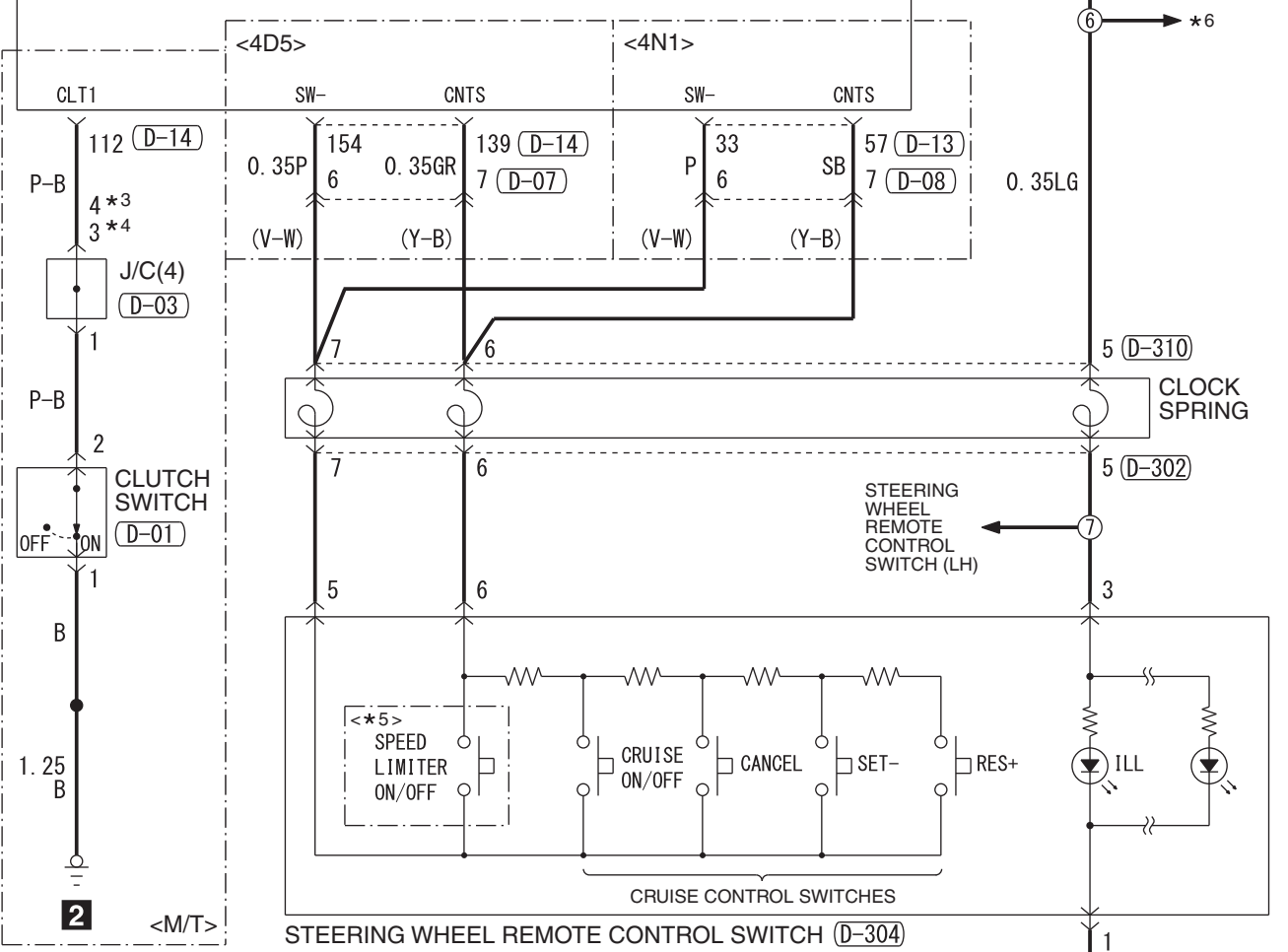

2

<M/T>

(D-13)

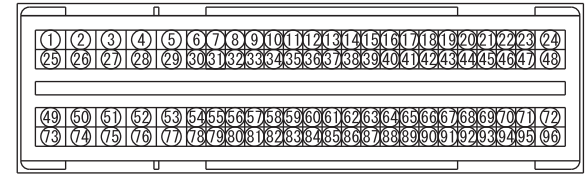

(D-14)

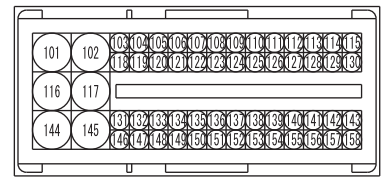

(D-302)

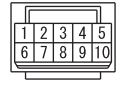

(D-304)

