

<Manual window>

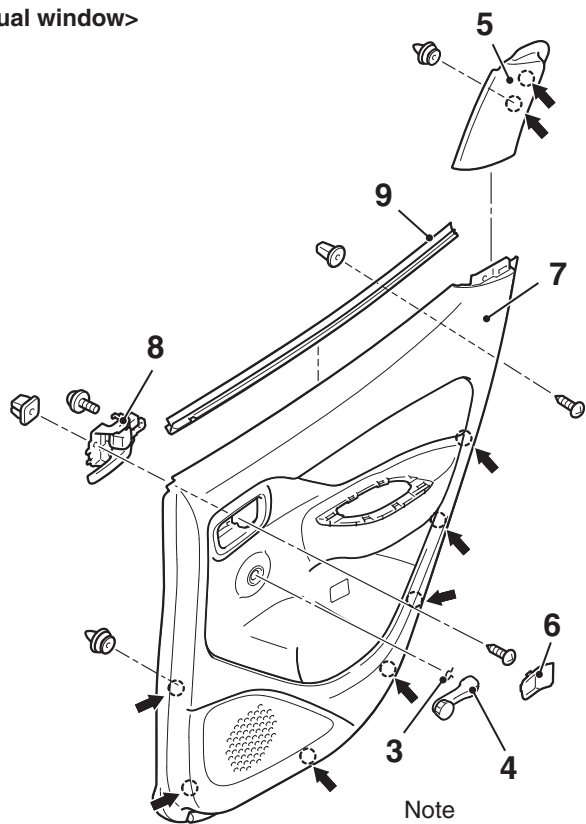

Note

← : Clip positions

← : Claw positions

