

ELECTRONIC-CONTROLLED THROTTLE VALVE (B-15)

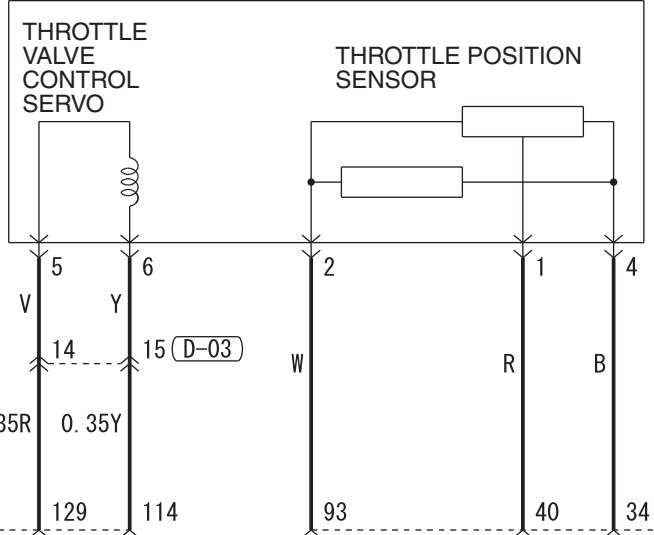

MANIFOLD ABSOLUTE PRESSURE SENSOR (B-35)

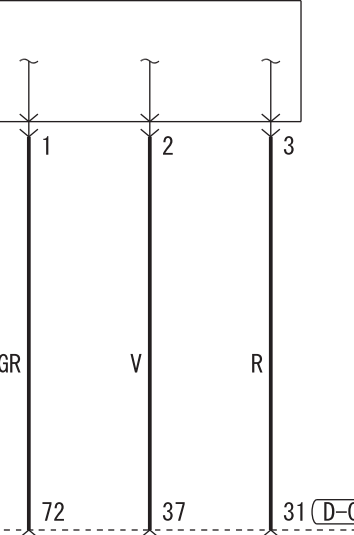

ENGINE-ECU

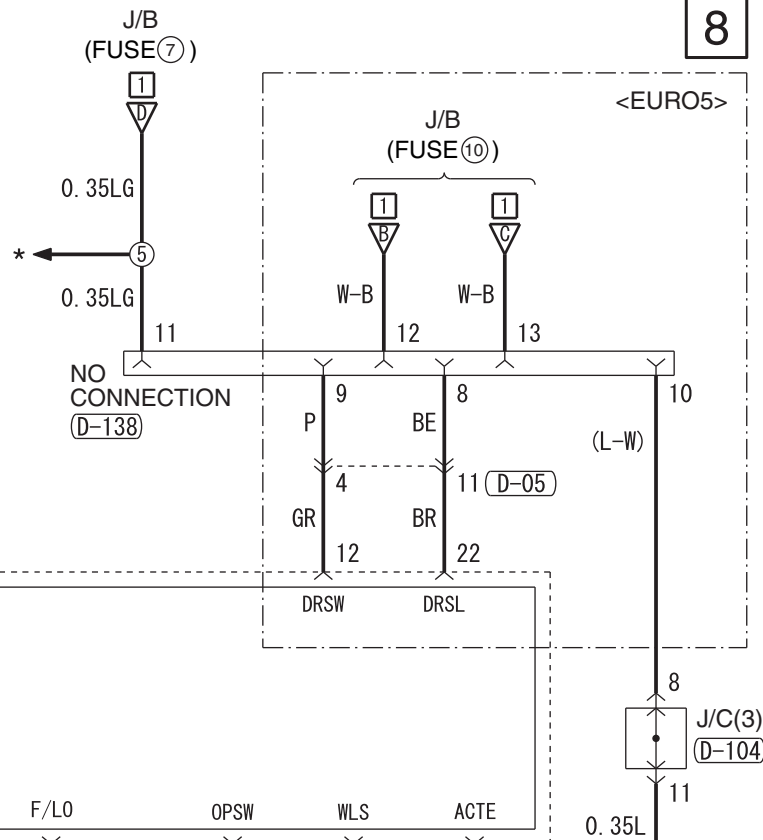
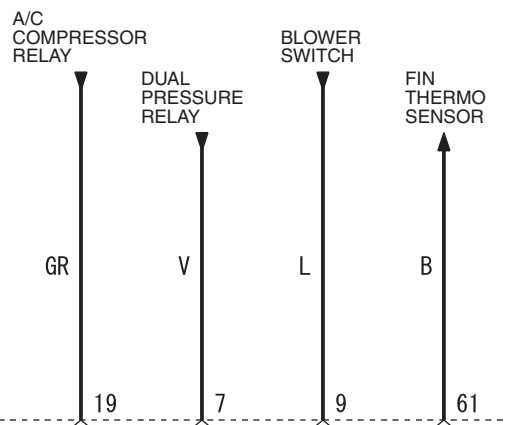
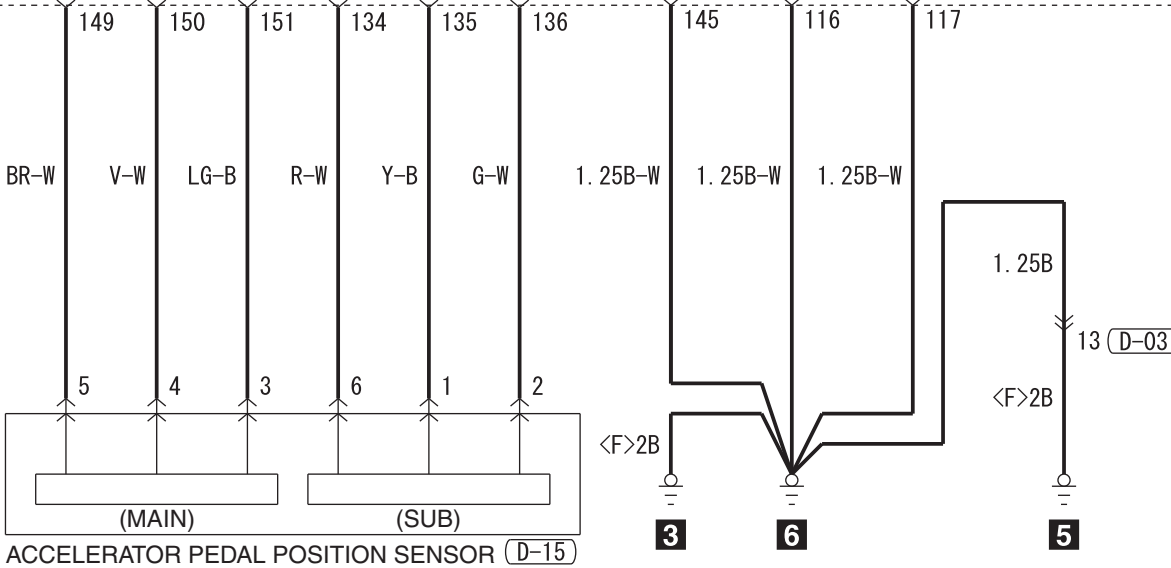
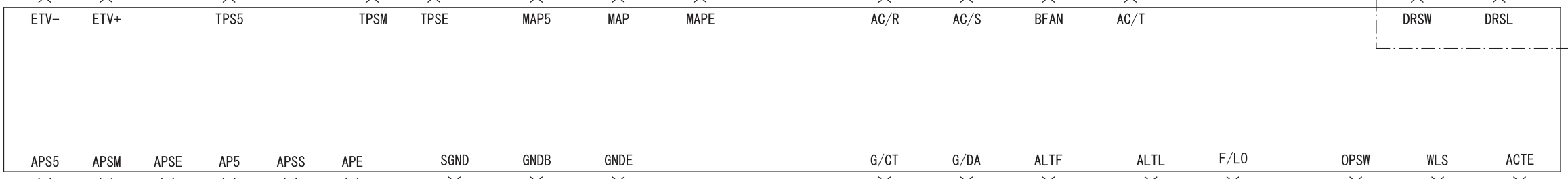

- NOTE
- \*: A/C-ECU
  - ASC OFF SWITCH
  - CLOCK
  - COMBINATION METER
  - CRUISE CONTROL SWITCH
  - DRIVE MODE-SELECTOR
  - GLOVE BOX LAMP
  - HAZARD INDICATOR ASSEMBLY
  - HEADLAMP MANUAL LEVELLING SWITCH
  - HEATED SEAT SWITCH
  - HEATER CONTROLLER ASSEMBLY
  - MULTIVISION DISPLAY
  - RADIO AND CD PLAYER
  - REAR DIFFERENTIAL LOCK SWITCH
  - SELECTOR LEVER ASSEMBLY
  - STEERING WHEEL MULTI-FUNCTION SWITCH
  - SPARE CONNECTOR (FOR AUDIO)

